

DOMESTIC COOKER HOSE

FLEXIBLE CORRUGATED S/S INNER COVERED WITH S/S BRAIDING AND YELLOW/CLEAR HYGIENIC WIPE CLEAN PVC COVER

COOKER HOSE ONLY

Part Number
GCHD/15/1250

SUITABLE FOR LPG
AND NATURAL GAS

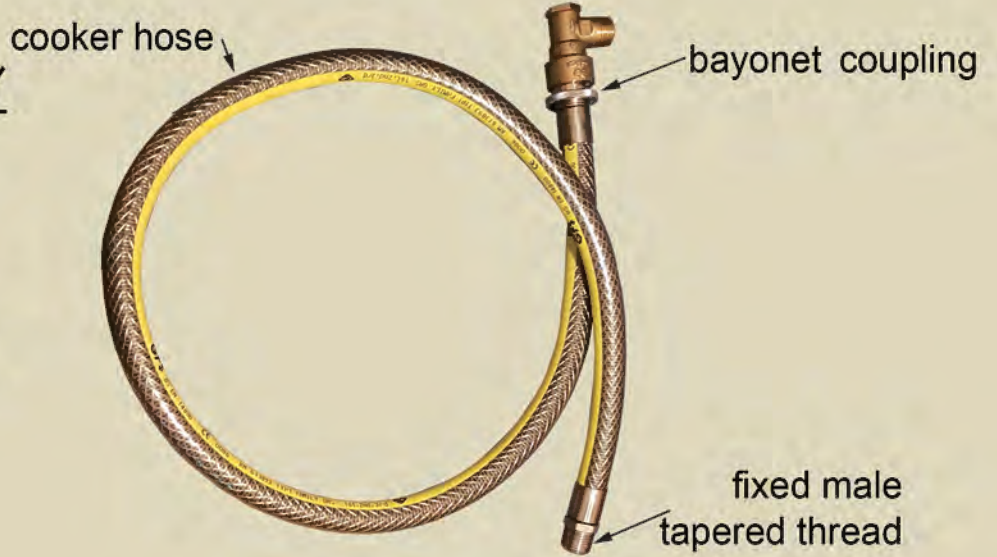

Restraining Strap (AVAILABLE SEPARATELY)

Part Number
GCHL/850

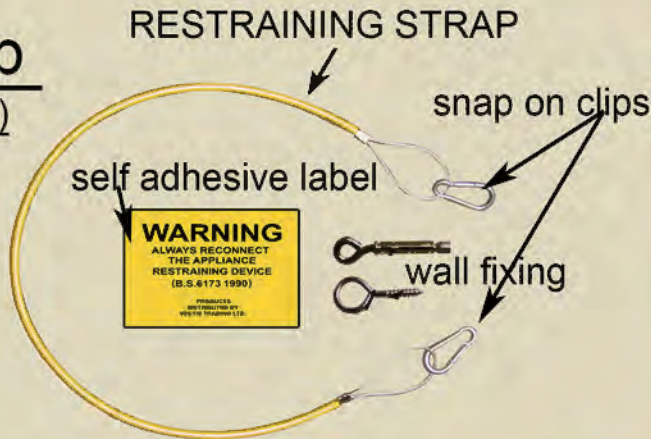

COMPLETE KIT

Part Number
GCHDCK/15/1250

SUITABLE FOR LPG
AND NATURAL GAS

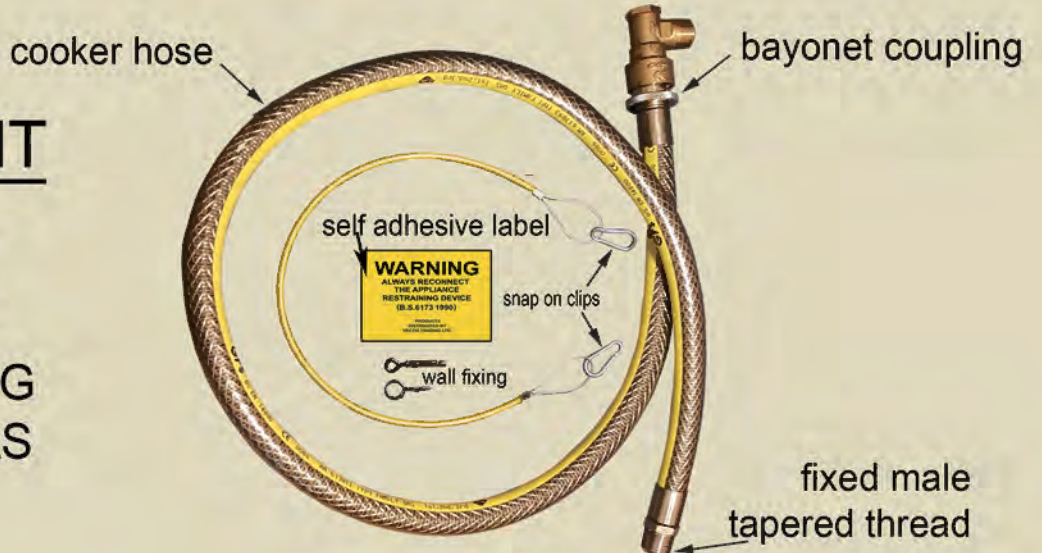

P2

COMMERCIAL GAS COOKER HOSES

FLEXIBLE CORRUGATED S/S INNER COVERED WITH S/S BRAIDING AND
YELLOW HYGIENIC WIPE CLEAN PVC COVER

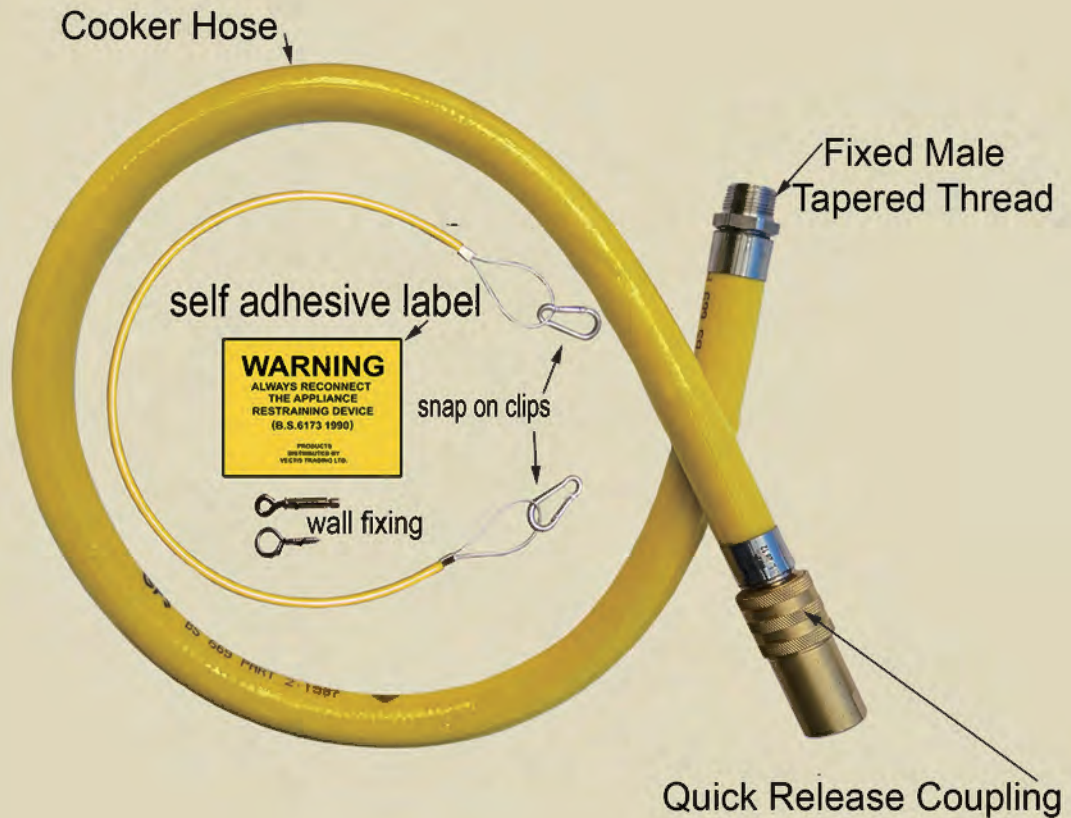

AVAILABLE IN 15mm, 20mm and 25mm

Part Numbers
GCHC/15/1250
GCHC/20/1250
GCHC/25/1250

**INCLUDED IN THESE KITS
ARE ALL AS SHOWN**

GAS CONNECTORS

FIXED LENGTH CONNECTORS

FLARED UNION ON ALL CONNECTORS AT BOTH ENDS. END FITTINGS AVAILABLE SEPARATELY

505 SERIES 15mm ENDS ONLY



FLEX 10mm ID

**505 SERIES
LENGTHS
AVAILABLE**

450mm
600mm
900mm

PART NO.

505F/450
505F/600
505F/900

615 SERIES AVAILABLE WITH 15mm or 20 mm ends



FLEX 15mm ID

**615 SERIES
LENGTHS
AVAILABLE**

450mm 1200mm
600mm 1500mm
900mm 1800mm

PART NO. FOR 15mm

615F/450 **615F/1200**
615F/600 **615F/1500**
615F/900 **615F/1800**

PART NO. FOR 20mm

615F/450B **615F/1200B**
615F/600B **615F/1500B**
615F/900B **615F/1800B**

GAS CONNECTORS (commercial)



LENGTHS AVAILABLE

600mm
900mm
1200mm

SIZES AVAILABLE

ALL FULL BORE
25mm
32mm

Larger sizes & lengths on indent

PART NO.

GFC/MF/600/25

GFC/MF/900/25

GFC/MF/1200/25

GFC/MF/600/32

GFC/MF/900/32

GFC/MF/1200/32

Fixed male tapered thread

Swivel union nut WITH NITRIL RUBBER SEAL

EXTENDABLE GAS CONNECTORS

EXTENDABLE STAINLESS STEEL GAS CONNECTORS

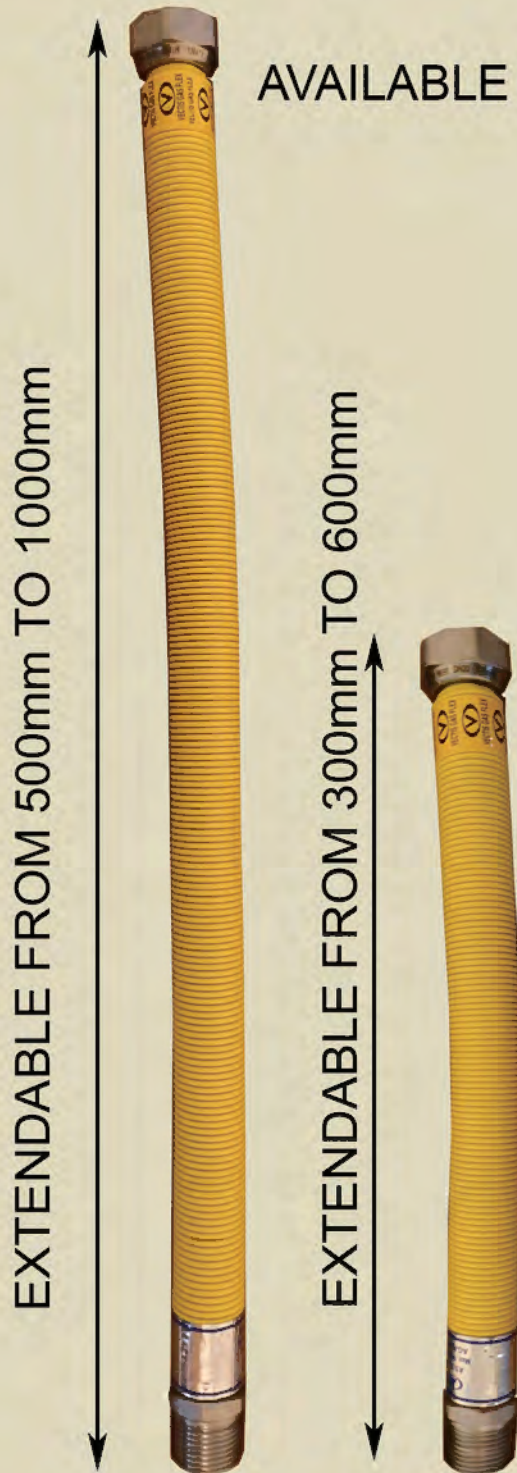

AVAILABLE IN 15mm and 20mm

PART No

15mm DIA

505F/300-600EX

505F/500-1000EX

20mm DIA

615F/130-220EX

615F/300-600EX

615F/500-1000EX

GAS CONNECTION KITS

**FIXED LENGTH
GAS HOB KIT**
Available in 15mm



450mm long
Pt No GHCK/200

600mm long
Pt No GHCK/600

900mm long
Pt No GHCK/900

**EXTENDABLE
GAS HOB KIT**
Available in 15mm

Pt No GHCK/300-600EX
EXTENDABLE FLEX FROM
300mm to 600mm long

Pt No GHCK/500-1000EX
EXTENDABLE FLEX FROM
500mm to 1000mm long



**EXTENDABLE
GAS APPLIANCE
CONNECTOR KIT**
Available in 20mm

Pt No GACK/130EX
EXTENDABLE FLEX FROM
130mm TO 220mm

Pt No GACK/300EX
EXTENDABLE FLEX FROM
300mm to 600mm

Pt No GACK/500EX
EXTENDABLE FLEX FROM
500mm to 1000mm



WATER CONNECTORS

FOR USE IN EXPOSED AREAS ONLY

FIXED LENGTH
STAINLESS STEEL
AVAILABLE IN 15MM DIA
LENGTHS
300mm
450mm
600mm

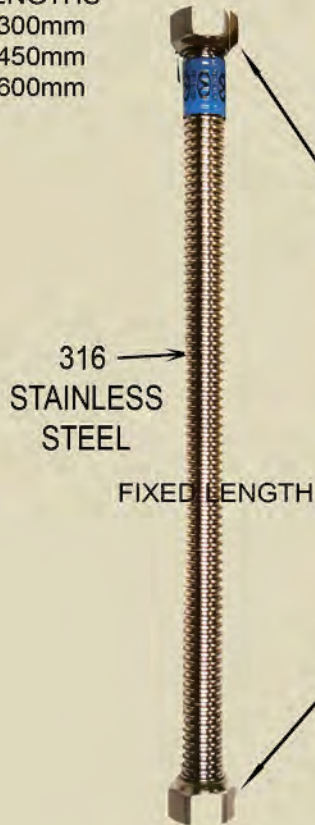

EXTENDABLE
STAINLESS STEEL
AVAILABLE IN 20MM DIA
LENGTHS
130mm to 220mm
220mm to 420mm
500mm to 1000mm

EXTENDABLE
STAINLESS STEEL
AVAILABLE IN 25mm DIA
LENGTHS
220mm to 420mm
500mm to 1000mm

304 STAINLESS STEEL
WHITE PLASTIC COATING

NICKEL PLATED
BRASS NUTS

316 STAINLESS
STEEL
304 STAINLESS STEEL

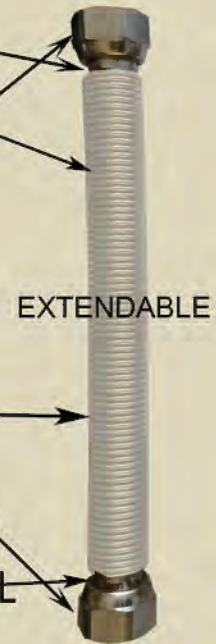

MAXIMUM PRESSURE RATING FOR WATER CONNECTORS
IS 500kpa. IF THE PRESSURE EXCEEDS THIS
A PRESSURE LIMITING VALVE MUST BE FITTED

PART NO
15mm DIA
S1241 NN/300
S1241 NN/450
S1241 NN/600



PART NO
20mm DIA
S3451EX/130-220
S3451EX/220-420
S3451EX/500-1000

PART NO
25mm DIA
S3452EX/220-420
S3452EX/500-1000



WE HAVE BRASS ADAPTERS FOR THE
20mm WHICH WE RECOMMEND TO
PROVIDE A GOOD SEALING SURFACE
FOR THE RUBBER GASKET PLEASE READ
WARNING LABEL ON THE PRODUCT

MALE/MALE - PT No V003DZR
MALE/FEMALE - PT No V004DZR

CONNECTIONS				
No	Type of Connection	Material	DN	inch
1	 Male Connection EN ISO 7/1 thread	Stainless Steel	12	1/2"
		AISI 304 (1.4301)	20	3/4"
2	 Swivel Female Connection EN ISO 228 1 thread	Internal Part: Stainless Steel	12	1/2"
		AISI 304 (1.4301)	20	3/4"
		Nut: Ni Coated Brass	25	1"

GAS CONNECTION KITS

INSTANTANEOUS GAS WATER HEATER CONNECTION KIT

FOR EXTERNAL SURFACE MOUNT INSTALLATIONS

Pt No GCK/100



MAXIMUM PRESSURE RATING FOR WATER CONNECTORS
IS 500kpa. IF THE PRESSURE EXCEEDS THIS
A PRESSURE LIMITING VALVE MUST BE FITTED

Suitable for most instantaneous
gas water heaters

GAS CONNECTION KITS

INSTANTANEOUS GAS WATER HEATER CONNECTION KIT

FOR EXTERNAL INWALL BOX INSTALLATIONS

Pt No GCK/200



MAXIMUM PRESSURE RATING FOR WATER CONNECTORS
IS 500kpa. IF THE PRESSURE EXCEEDS THIS
A PRESSURE LIMITING VALVE MUST BE FITTED

Suitable for most instantaneous
gas water heaters

CISTERN FILL VALVES

AVAILABLE in 10mm or 15mm inlet
BOTTOM ENTRY



Easyfit
Fastfill
Height adjustable
Removable filter
Suitable for all pressures up to 689kpa or 100psi

Part No. VFBVE/15BT
Part No. VFBVE/10BT



CARTON QUANTITY 25

SIDE ENTRY BRASS TAIL

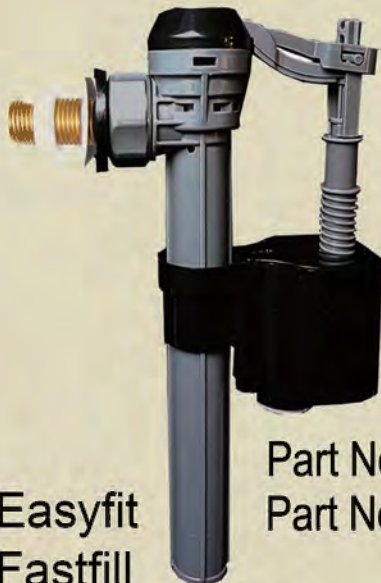

Easyfit
Fastfill
Removable filter
Union connection inside cistern
Suitable for all pressures up to 689 kpa or 100psi

Part No. VFBVE/15BT
Part No. VFBVE/10BT



CARTON QUANTITY 20

CISTERN FILL VALVES

PREMIER RANGE

All adjustments and servicing can be carried out at the top of the valves
no need to disconnect the water connection

BOTTOM ENTRY BRASS TAIL

Available in 10mm and 15mm

Part No
VPFV/15BE
VPFV/10BE

HIGHLY INTERGRATED
DESIGN NARROW PROFILE



ONCE THE HEIGHT HAS BEEN SET
IT MUST BE LOCKED

Easily serviced
service kit comes
with seals already fitted
Clean or change filter



CARTON QUANTITY 40

Bottom and Side Entry Fill Valves are

- Easyfit
- Fastfill
- Removable Filter
- Suitable for all pressures
up to 689kpa or 100psi

SIDE ENTRY BRASS TAIL

Available in 15mm

Part No
VPFV/15SE

HIGHLY INTERGRATED
DESIGN NARROW PROFILE



Easily serviced
service kit comes
with seals already fitted



CARTON QUANTITY 36

FOR SERVICING AND KITS REFER TO PAGE 16

CISTERN FLUSH VALVES

AVAILABLE in 40mm or 50mm Outlets
(40mm Does Not Include Doughnut Ring)

Part No VDFV/50

Part No VDFV/40

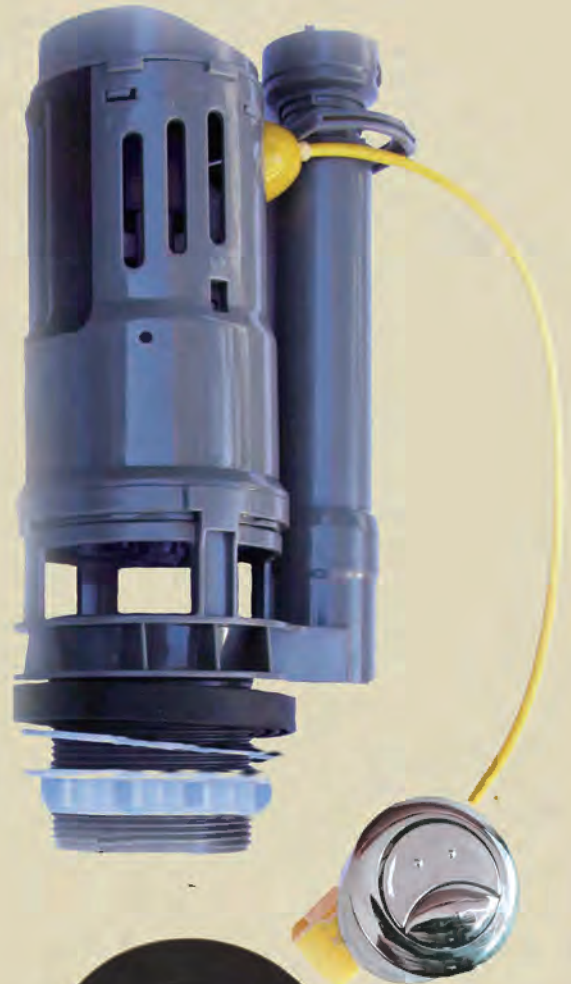

Extended thread length to enable a flush pipe to be connected if required. Any excess thread can be cut off when connecting to close coupled suites otherwise it could restrict the flush.

Doughnut ring included for close coupled suites

Extra flanges in chrome and white to enable the flush buttons to fit most cisterns using one outside the lid the other inside as a backing flange.

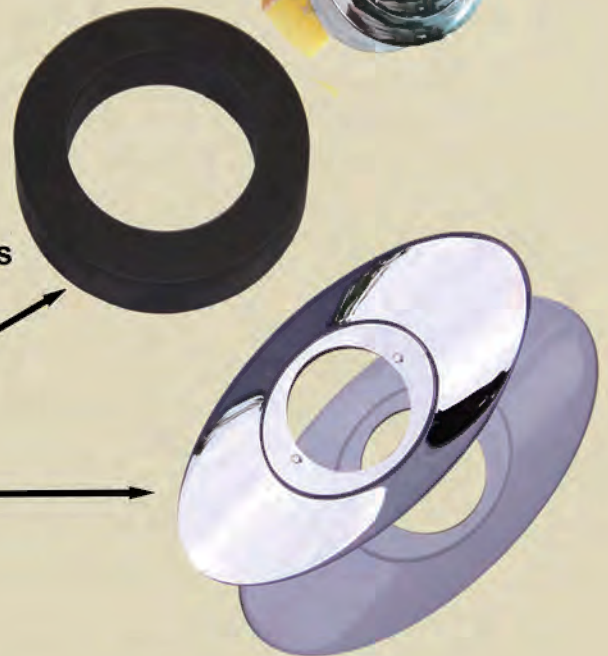

INWALL CISTERN FLUSH VALVE

MULTI-FIT

FITS MOST INWALL CISTERNS

PART No. VDFV/50/IW

ATTENTION

ADJUSTABLE HEIGHT
OVERFLOW

TOP ENTRY CABLE
TO AVOID
OBSTRUCTIONS
INSIDE CISTERN

TO FIT THE FLUSH VALVE IN AN
INWALL CISTERN ADEQUATE
ACCESS IS REQUIRED
AT THE TOP AND BOTTOM OF
THE CISTERN, PREFERABLY
BEHIND THE CISTERN

ADJUSTABLE HALF
AND FULL FLUSH

COMPLETE WITH CP FLUSH BUTTON
AND EXTENDED CABLE 450MM LONG
AVAILABLE WITH 50MM OUTLET

Extra flanges in chrome and white to enable
the flush buttons to fit most installations using
one outside the wall the other inside
as a backing flange.

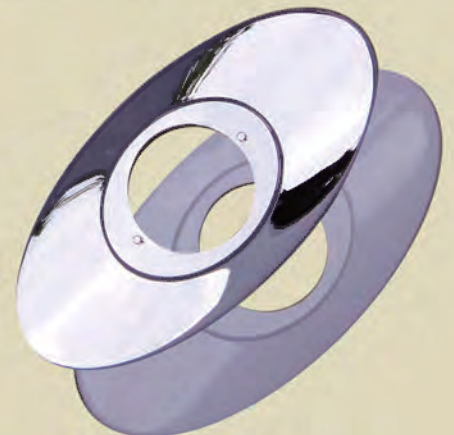

FOR SERVICE PARTS & WASHERS REFER TO PAGE 15 & 16

AUTO FLUSH KIT

SINGLE FLUSH HAND WAVE OPERATED PART No VAFK/50

Suitable for the elderly, children, the disabled and helps to reduce bacteria. Operated by hand wave, comes complete with flush valve, electronic unit, chromed cover plate to cover holes left by removal of the existing buttons. Requires four AA alkaline batteries. Electronic unit and battery box has IP65 water resistant rating. Fits most cisterns with 50mm outlet. All parts concealed in the cistern only chromed cover is visible



SIZE OF
ELECTRONIC UNIT
IN PERSPECTIVE



CHROMED SELF ADHESIVE
COVER FOR THE HOLE LEFT
BY REMOVAL OF BUTTONS



IDEAL FOR

Elderly people
Children
Disabled
Reducing bacteria

Imported and Distributed by: Vectis Trading Ltd
P.O. Box 3034, Teapoo, New Zealand, PH 077770116

www.vectis.co.nz

S/S BRACKET



NEW FLUSH
VALVE IN KIT

ENLARGED PICTURE

ELECTRONIC UNIT

BATTERY PACK



ACCESS DOORS

Pt No AD200 - 200mm x 200mm

Pt No AD350 - 350mm x 350mm

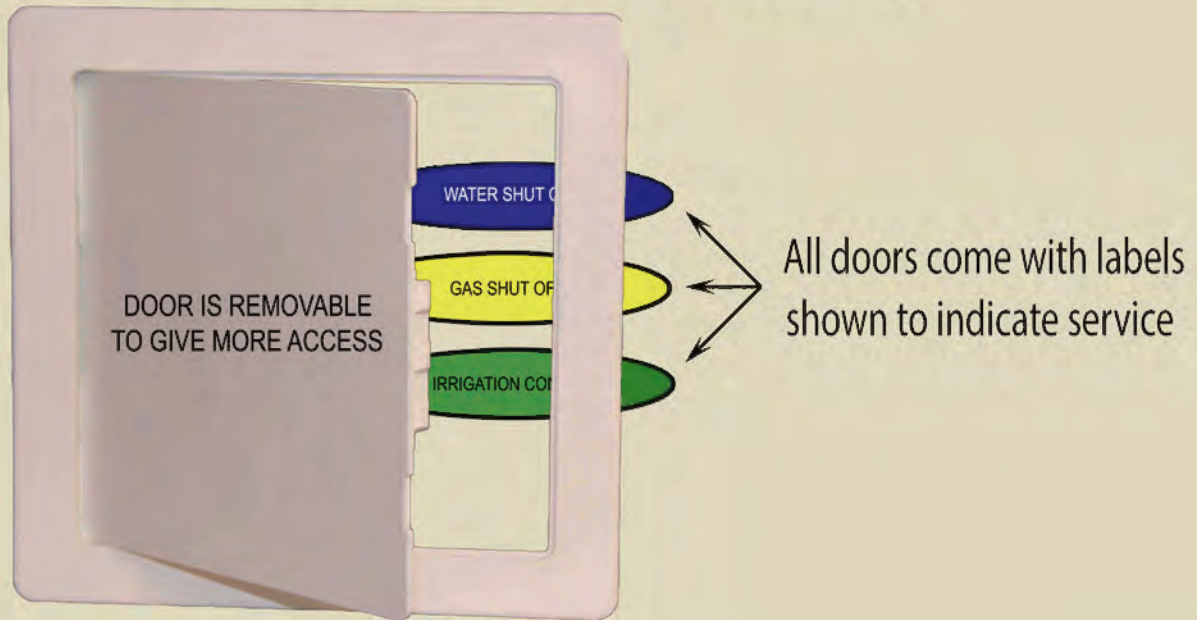

TOOLS

NIPPLE EXTRACTORS

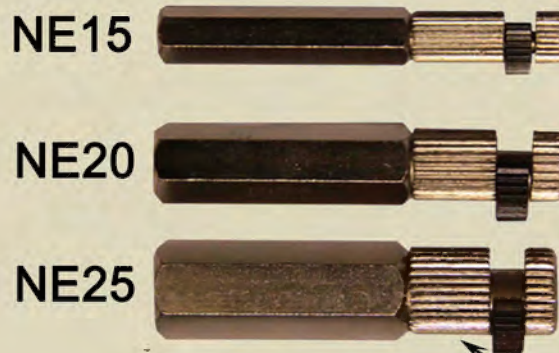

If the extractor is not inserted at least up to this point on all sizes breakage will occur to this swivel and is not covered by warranty

FLUSH VALVE PARTS

BUTTON SETS IN CHROME ONLY



PRE 2009
SINGLE FLUSH BUTTON
SET COMPLETE WITH
BACK NUT
PART NO VVDFB/S/MK1



PRE 2009
DUAL FLUSH BUTTON
SET COMPLETE WITH
BACK NUT
PART NO VVDFB/MK1



AFTER 2009
DUAL FLUSH BUTTON
SET COMPLETE WITH
BACK NUT
PART NO VVDFB/MK2



AFTER 2018
DUAL FLUSH BUTTON
SET COMPLETE WITH
BACK NUT
PART NO VVDFB/MK3

COVER FLANGES

COME AS A SET
CHROME & WHITE

PRE 2009 PART NO. VVDFF/MK1

AFTER 2009 PART NO. VVDFF/MK2

AFTER 2018 PART NO. VVDFF/MK3



CHROME

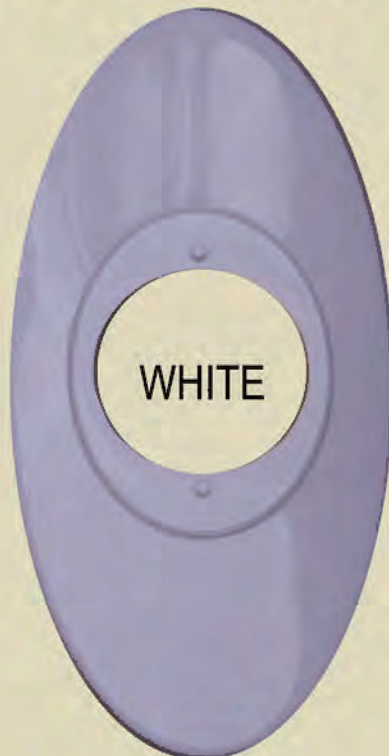

WHITE

DOUGHNUT WASHER
PART NO. VVDW/50



SERVICE KITS

FILL VALVE SERVICE KITS

PRE 2009
PART No VSKSE&BE
SIDE AND BOTTOM ENTRY
PLASTIC TAIL



AFTER 2009
PART No VSKBE/MK1
BOTTOM ENTRY BRASS TAIL



AFTER 2009
PART No VSKSE/MK1
SIDE ENTRY BRASS TAIL

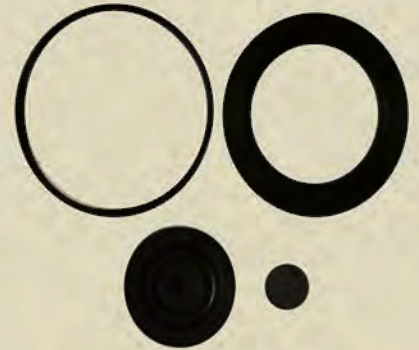

UNDERWATER VALVE WASHERS

UNDER WATER VALVE WASHERS
ARE SOLD IN PACKS OF 5 AND 10 ONLY



PREMIERE FILL VALVES

BOTTOM AND SIDE ENTRY
PART No VPFV/SK



TO REMOVE THE SERVICE KIT
TURN THE ARROW CLOCKWISE TO THREE O'CLOCK
AND PULL OUT

TO FIT THE SERVICE KIT
ENTER THE YELLOW SERVICE KIT
PART OF THE WAY IN
WITH THE ARROW AT TWELVE O'CLOCK
TURN CLOCKWISE TO THREE O'CLOCK
PUSH ALL THE WAY IN
AND TURN ANTI CLOCKWISE TO TWELVE O'CLOCK

